

West Area Planning Committee Presentation

17/01860/FUL

9 Union Street
Oxford
OX4 1JP

21

www.oxford.gov.uk



**OXFORD
CITY
COUNCIL**



Agenda Item 4

Site Location Plan

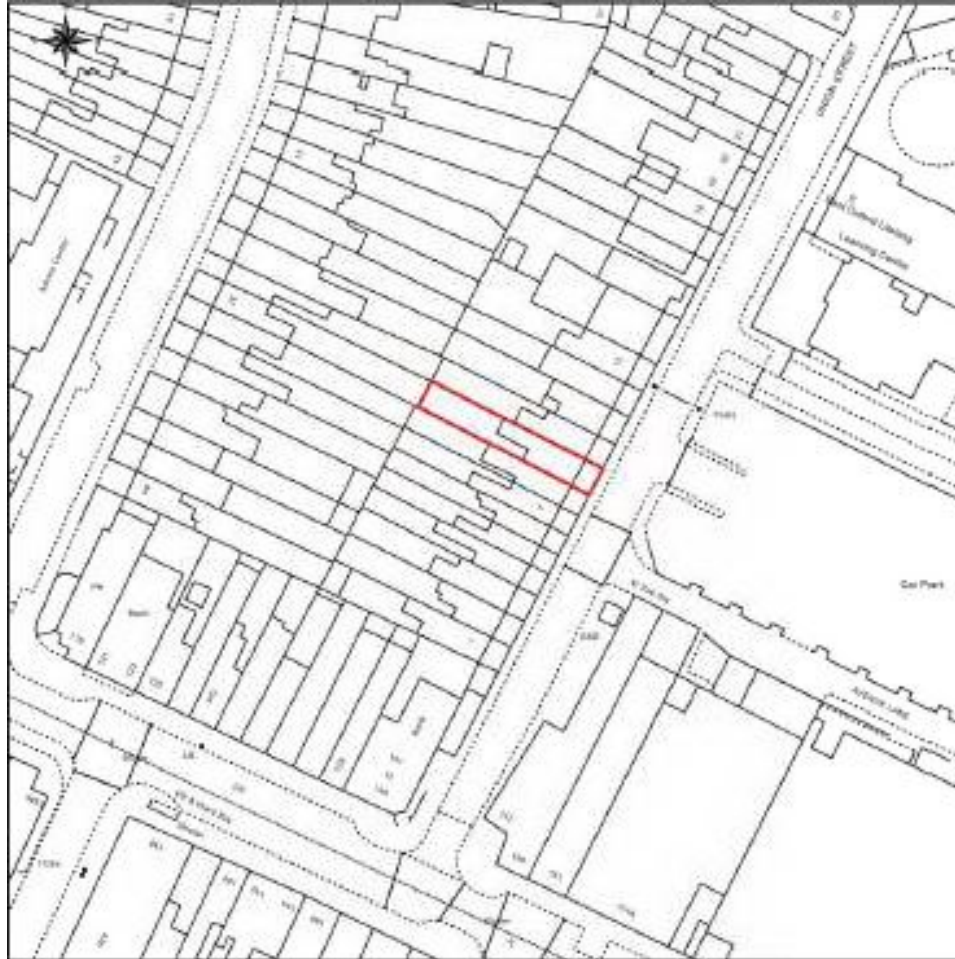



Rear Elevation 9 Union Street



View towards 8 Union Street

Existing Floor Plans & Elevations

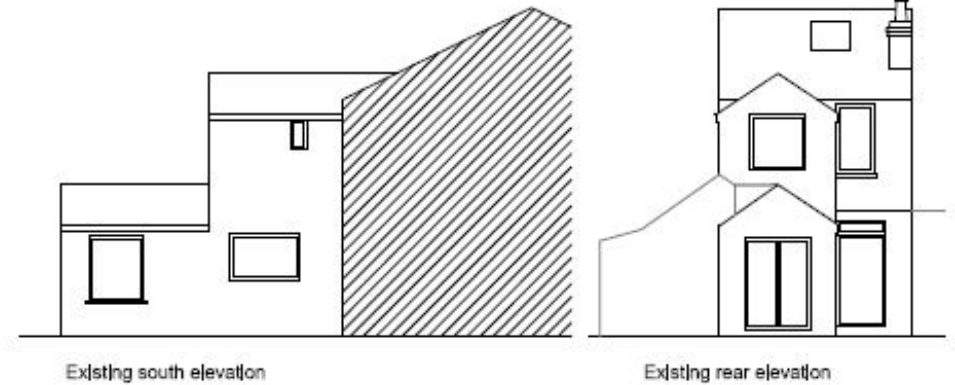
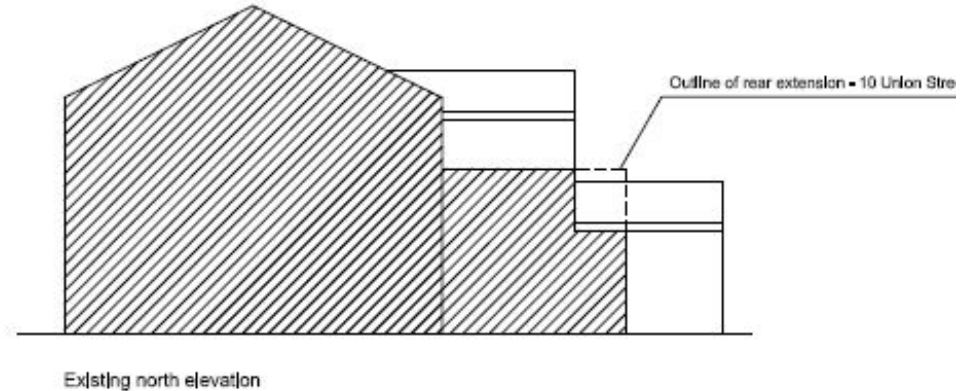
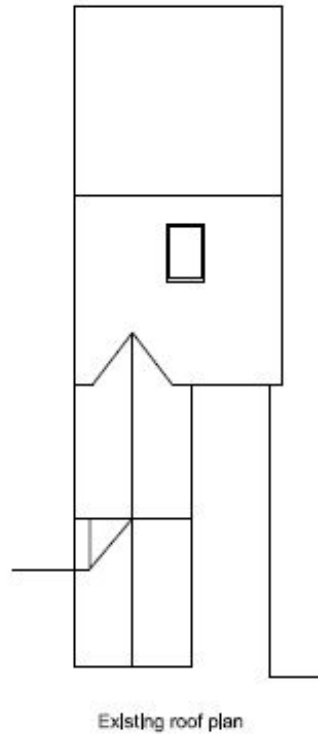
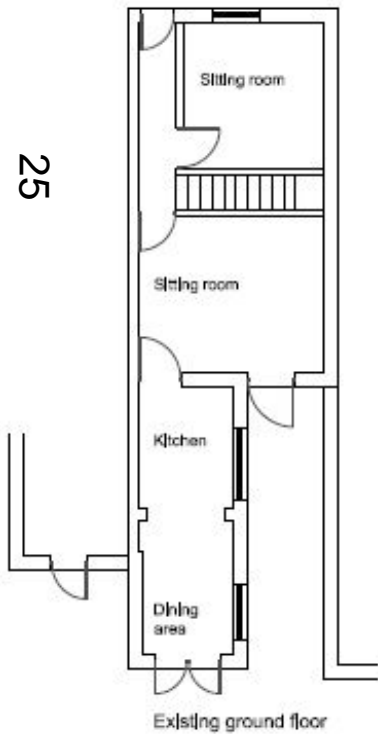

Proposed Floor Plans & Elevations

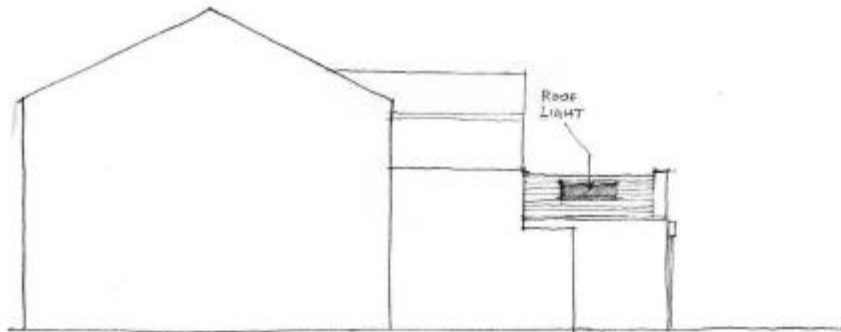

PROPOSED NORTH ELEVATION

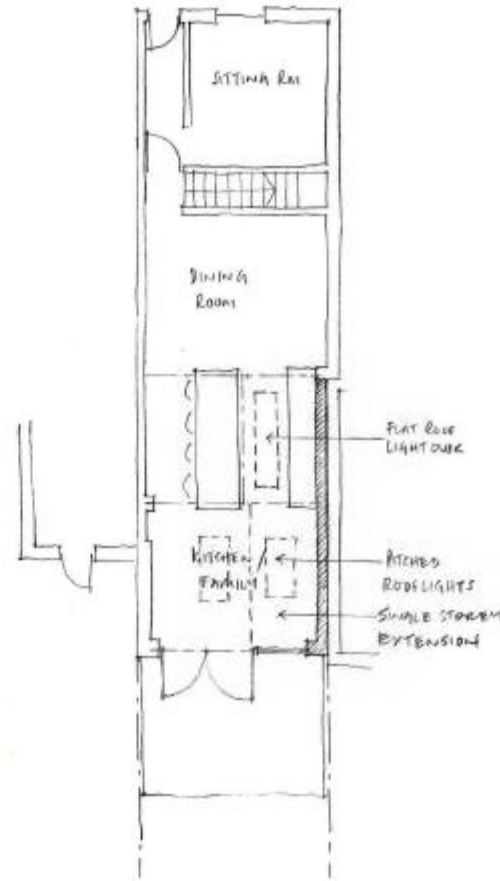

PROPOSED GROUND FLOOR

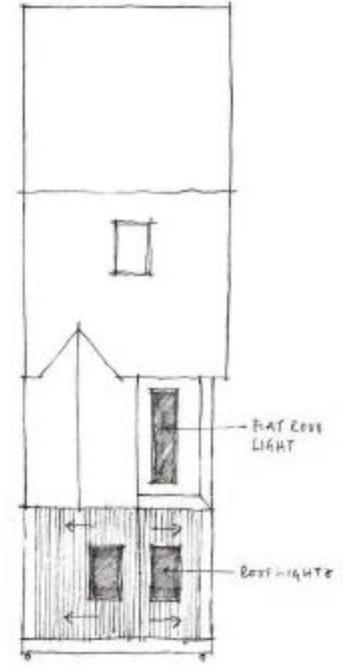

PROPOSED ROOF PLAN

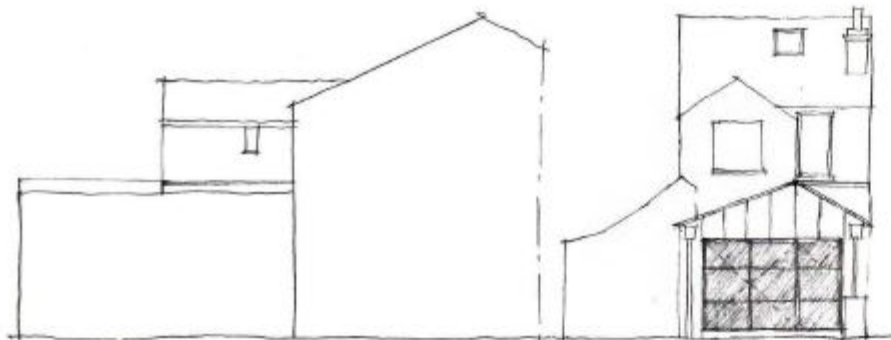

PROPOSED SOUTH ELEVATION

PROPOSED REAR ELEVATION

26

hudson **architecture** studio
 client: Miss Nadia Robinson
 project: 9 Union Street, Oxford
 17_019 PLA_001
 drawing: Planning drawings
 scale: 1/100
 AH

